

Optimised semiconductors help in making robots collaborative

By Clemens Müller, Infineon

The robotics revolution has spawned a new type of industrial robot – the so-called collaborative robots. They feature advanced sensor and control components that limit power and force in order to eliminate critical collision situations entirely. Modern microcontrollers with safety functions, high-speed precision sensors as well as efficient power components enable these robots to work safely with, and not just for, humans.

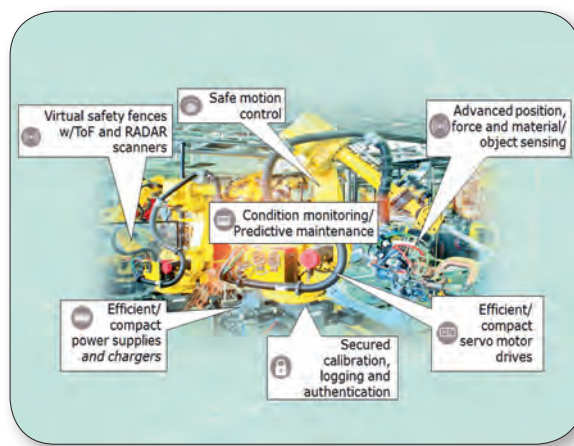

Figure 1. There is a broad application field for modern semiconductor products relating to the new generation of robots.

There is a new generation of robots on the rise which is about to revolutionize the way production lines in modern factories are set up. This new generation is called collaborative robots, otherwise known as cobots. They work alongside people, support them in the respective manufacturing processes and increase the quality of the finished products thanks to their highly precise and safe working methods. Unlike classic industrial robots, cobots work without a safety cage and interact directly with humans. To meet the associated requirements, their design must incorporate certain characteristics. In particular, special safety measures are required so that robots and humans can work together safely.

The most important design criteria for cobots are sensitivity with respect to their working environment, low system weight and small form factors achieved by high power density and tightly integrated electronics. High precision, integration and efficiency as well as different topologies in terms of number of axes, joints and motors are additional important issues. Another major aspect comprises security as a prerequisite for functional safety, which means protection against any unauthorized modification or even criminal manipulation as well as safeguarding of intellectual property such as algorithms implemented in software. They are very often the

key differentiating aspects among different cobot platforms. With intelligent, integrated and efficient semiconductor solutions, these requirements can be met in the development of modern collaborative robots, but also conventional industrial robots are profiting. And the market offers potential. For 2015, sales in the market for industrial robots reached nearly \$10 billion worldwide. Between 2015 and 2020, analysts are predicting a growth of about 23% for the collaborative robots alone.

Functional safety is essential for all robots, especially if they are used in a collaborative setting, working closely with humans. Aspects like system redundancy, highest quality constraints etc to achieve functional safety are one part of the equation. Because robots can only be truly functionally safe when they are embedded in secure systems. This is an aspect which is increasingly important in the context of tightly connected Industry 4.0 and industrial IoT system solutions. Encryption is used to ensure that the robot only executes functions it has been programmed for and that critical data such as calibration data cannot be manipulated. In particular, the robots as part of the manufacturing process are secured against manipulation in case of wired or remote software updates. Security also requires secure authentication of individual users and various access permission levels

as well as the authentication of newly added or replaced components. Calibration is necessary for the correct functioning of the robot. If, for example, a hacker manipulates the calibrations, the robot could then exceed the given limits of movement. This is where security and safety converge – without efficient security protection, there is no functional safety. This is an important requirement for future systems, which is addressed by dedicated security controllers (OPTIGA family) or AURIX microcontrollers with features such as the HSM (Hardware Security Module). Since the security functions are implemented in the hardware, users require only little detailed knowledge of encryption technologies. In addition, the impact on existing software implementations is extremely low!

There is a broad application field for modern semiconductor products relating to the new generation of robots. The spectrum ranges from motor control, high-performance position and object detection, efficient and compact drives, efficient and compact power supplies and chargers, and the implementation of virtual safety gates to security functions with secure authentication and calibration. In addition, IP protection, especially for start-up companies whose know-how is based on the algorithms, is essential. A key criterion for the new generation of robots



Figure 2. At Infineon's Dresden production facility, a robot is used which can also anticipate directions of movement. It works with ToF 3D cameras, and will make use of a redundant 24 or 60 GHz radar system.

is a design that is as compact as possible, in particular a space-saving and efficient motor control unit. This is made possible by IGBTs or low-resistance MOSFETs (e.g. OptiMOS), highly integrated gate drivers with built-in protection and integrated power modules, so called IPMs that combine the complete power control infrastructure within a single package. Advanced robot control algorithms rely on highest precision parameter capturing such as torque, position, pressure, etc with corresponding sensors. Data then needs to be processed with powerful safety controllers such as the AURIX family.

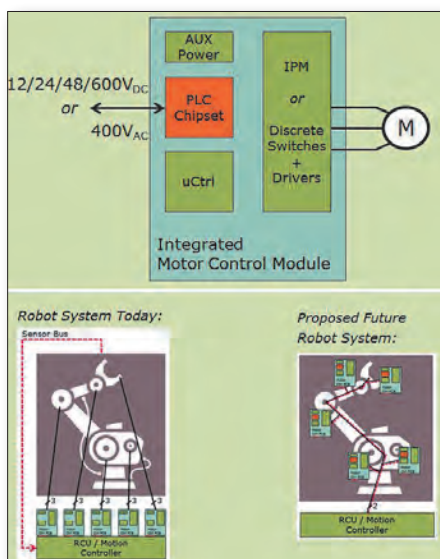

Figure 3. Thanks to modern semiconductors and the integration of powerline-like modulation along with the motor control electronics, the number of cables in a robotic arm can be reduced from nearly 30 down to just 2 or 3.

If you want to liberate robots from their cages, it is necessary to ensure that people do not even come within the critical range of a robot working at high-speed and precision, which could result in them being injured either through their own fault or malfunctions. Designing robots with the corresponding degree of sensitivity is only possible with sophisticated sensor technology. Basically, it is important to make the area between the person and robot safer, and also between robots themselves. This is about making the protection zones more flexible; i.e. that a greatly reduced protection zone moves along dynamically with a moving robot arm, for example. A zone concept is used when implementing the virtual fences. By way of example, only a warning signal is triggered when approaching in the first warning level, whilst the robot continues to operate at full speed. On approaching further, the speed is then reduced with the corresponding warning. Only in the immediate danger area does the robot stop.

Corresponding protection mechanisms require extremely precise 3D object recognition. Redundant sampling ensures maximum functional safety. It is also helpful to capture the direction of movement, for example whether a person approaches and then moves away again, or whether they enter the danger area. Intelligent detection of the actual danger situation prevents unnecessary downtimes or slowing down of the robot work – and accordingly production losses and costs. In this area, Infineon is working with partners on time-of-flight concepts (ToF) and radar sensors. This solution allows the environment to be scanned in 3D at more attractive system costs than with traditional LIDAR scanners.



Figure 4. Based on an Arduino shield, a monitoring/sensor box supplies the data needed for predictive maintenance.

On the basis of the 3D resolution and using special algorithms, it is possible to anticipate the directions of movement, for example. The prototype of a robot, which recognises its surroundings with ToF 3D cameras, and which in future will be able to anticipate directions of movement, has already been successfully tested at the Infineon production facility in Dresden. A redundant, sensor fusion-based extension to 24 or 60 GHz radar systems is in preparation.

Traditionally, an industrial robot is based on a central motor control and numerous drives in the axes. This requires a considerable amount of wiring for a typical robot arm with thick motor cables (3 or more phases) per motor, plus an additional communication bus for control purposes and reading out sensor data. Thanks to modern semiconductors and the integration of powerline-like modula-

tion (power line communication technology, PLC) together with the embedded motor control electronics, this outlay can be significantly reduced and thus also weight and overall system costs. In initial laboratory experiments, Infineon has succeeded in reducing the number of cables in a robot arm from almost 30 down to only 2 to 3.

At the same time, although no algorithmic or electrical optimizations have been made, transmission speeds of well over 100 Mbps were achieved. The potential for optimized parameter tuning is well understood and will be addressed together with partners on a ready-to-use servomotor control prototype, which will allow testing of the technology within realistic application scenarios. Less wiring not only means lower weight but also fewer interfaces. Since this is important for harsh manufacturing environments it can be

translated into increased reliability. An initial prototype of such a motor control, for which Infineon is integrating the necessary components, is in preparation. The corresponding PLC chipset and coupling devices for supporting 12, 24, 48, 600 V DC or 400 V AC will be directly integrated into the inverter modules at a later time. This way it will be optimally adapted to the existing power electronics and the switching algorithm within the inverter stage. Thanks to the intended integration of PLC technology and the higher power density of the motor electronics, it will be easy for the development teams to install locally controlled motors directly in the axes of the robot.

Systems associated with Industry 4.0 also require efficient predictive maintenance. The status of the motors, their controls and the entire system have to be queried non-invasively by monitoring the voltage, current strength, frequency, temperature, pressures, noises, gases, etc. Subsequently, the data has to be processed and compared with reference values on the basis of machine-specific algorithms and sensor values. With corresponding monitoring, downtimes can be reduced and the foundations laid for Industry 4.0. Allowing engineers to develop their own monitoring and prediction algorithms, Infineon has built up a sensor box for prototyping purposes, which can be connected via Wi-Fi or USB to a PC. Users can randomly select up to two Arduino shield-like sensors that can be plugged on top of each box. Up to four boxes can be connected via a USB hub to a total of eight sensors, such as silicon microphones, pressure, current, angle, CO₂, radar and magnetic 3D sensors. All sensor data is being provided in a digitalized format. Thanks to the broad sensor portfolio, this prototyping solution enables interested customers to select the optimum set of sensors for their monitoring function, and to easily develop their own algorithms for each particular application they require. ■