

Kontron's ARM-based COM solutions and software services



Peter Müller

**Product Line Manager COMs
Kontron**

Munich, 4th July 2012

» Why ARM COMs?

- new markets for mobile applications are developing
- ARM reaching performance level of X86
- COMs allowing better TTM and reduce overall TCO for ARM processor-based products

» How?

- Creating scalable building blocks for application ready platforms

» Module products planned for 2012:

- ULP-COM with Texas Instruments Sitara 3874
- ULP-COM with Freescale i.MX6
- ULP-COM with NVIDIA Tegra 3

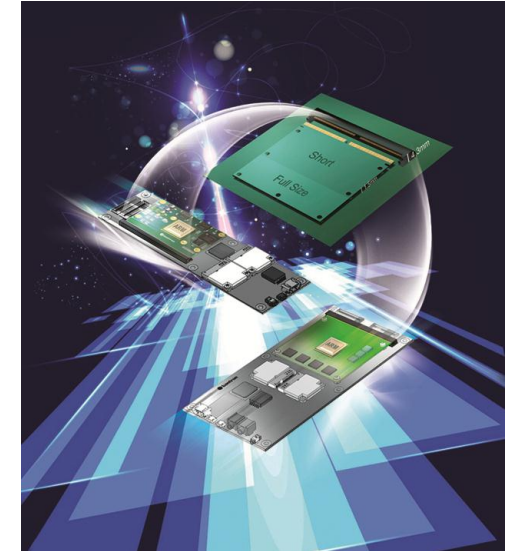

ARM Computer-on-Modules

Positioning

beyond x86

ARM +

Parallel TFT display bus
MIPI display interface
Camera interfaces
Multiple SPI links
Multiple SDIO interfaces
Serial ports / MOST

Designed for mobility

Many USB (8 lanes)
Lots of PCI Express (6 lanes)
PCI Express graphics (16 lanes)
LPC (an x86 only bus)
.....and more

X86 +

Designed for highest PC performance

ARM COM Designs requires fewer pins and lower cost power circuitry

- » ARM processors are powerful enough to drive a graphical user interface at very low power consumption, (Smartphone, Tablet)
- » ARM delivers exceptional performance/watt ratio
 - No bulky thermal solution
- » Extreme low power consumption at operation (<2W)

ARM better serves Ultra Low-Power market requirements

- » Extended temperature selections available
- » SOC performance with dual/quad core is comparable with ATOM range
 - ARM will not replace Intel x86 technology. Rather, it reaches segments that are currently underserved relative to ARM
- » Longevity up to 10 years

Why ARM needs a new COM
Form Factor?

form factor

» Different requirements in mobile / portable applications

- Housing constraints
- Thermal limits
- Power / battery life focus
- cameras, very small displays etc.



» COM Express® pin-out is optimized for x86 features – ARM platforms miss many of X86 ports

» ARM processor based & optimized for low-power mobile apps supporting very small displays, cameras etc.



- » A new COMs standard incorporating ARM® technology
 - Form factor based on MXM3 connector
 - Optimized pinout for ARM
 - Alternative solution to x86 based COM apps

- » Standard to be hosted at recently founded SGET standardization group (www.sget.org)
- » ULP-COM is a building block solution
 - ULP-COM Module + carrier = scalable / flexible architecture
- » Ecosystem support
- » Layers of support to enable complete solution
- » ROI maximization via faster TTM and long life support.
- » Kontron is your partner for ARM solutions



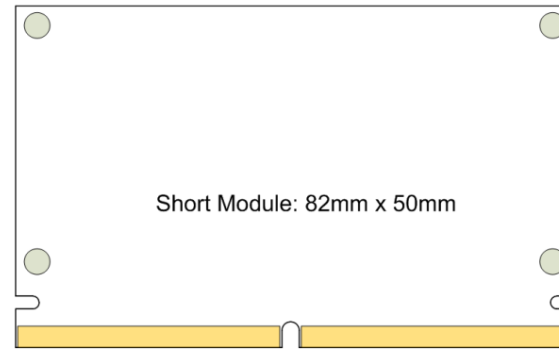
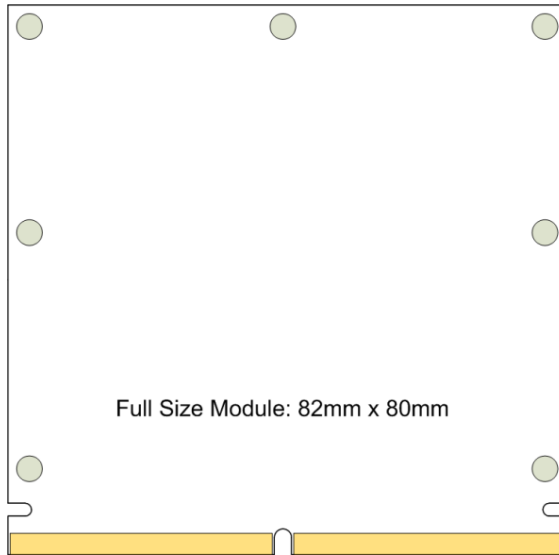

» MXM 3.0 connector:

- 314 total pins available
- Multiple Sources, High Volume
- Shock-/vibration approval for automotive optional

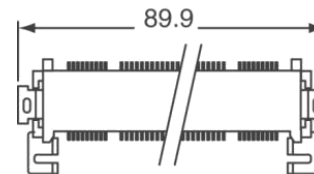

» Ultra Low-Power-COM meets application needs

» Enclosure constraints

- Limited x,y & z dimensions
 - Small surface area 4100 mm²
 - Height < 6.0mm – top and bottom
 - Height match with SOC silicon and components
- Mechanical considerations
 - Connector style enables low profile insertion

» Thermal limits

- < 5W TDP - easy thermal solution

» Power / battery life

- Small Module + smaller battery enables reduction of application envelope

Figure 3 Module Minimum 'Z' Height

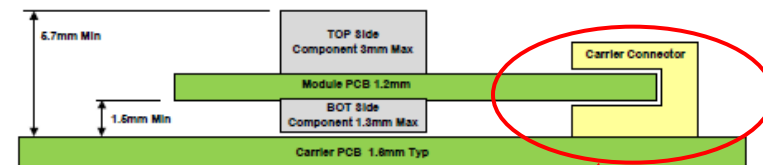

MXM3.0 connector

Kontron Low Power ARM Architecture - Supported Interfaces



| Pin Group | Pin Count | Description / Primary Function | Alternate Function |
|---------------|-----------|---|--------------------|
| Parallel LCD | 28 | Primary Display: 24 bit parallel RGB data | |
| LVDS LCD | 10 | Primary Display: Single channel 18 / 24 bit LVDS data | eDP |
| LCD Support | 4 | Panel and backlight enable, PWM, dual pixel clock | |
| HDMI | 12 | Secondary Display: HDMI | DP |
| CSI0 / PCAM | 7 | Camera Input: CSI 2 lane / Parallel Camera Input D10:15 | |
| CSI1 / PCAM | 10 | Camera Input: CSI 4 lane / Parallel Camera Input D0:9 | |
| PCAM Support | 6 | Parallel Camera support signals | |
| GBE | 12 | Gigabit Ethernet | |
| PCIe | 28 | 3 PCIe x 1 ports with supporting signals | |
| USB | 11 | 3 ports, one is OTG (client or host); other 2 host only | |
| SATA | 5 | 1 port (may be boot device) | |
| SDIO | 9 | 1 port 4 bit | |
| eMMC | 11 | 1 port 8 bit (may be boot device) | |
| SPI | 10 | 2 ports (one of the two may be a boot device) | |
| I2S | 13 | 3 ports plus Audio master Clock | |
| SPDIF | 2 | 1 port | |
| I2C | 8 | 4 ports | |
| Serial | 12 | 4 ports (two 2 wire and two 4 wire) | |
| CAN | 4 | 2 ports | |
| GPIO | 12 | General Purpose I/O (4 additional GPIO via Strap pins) | |
| Boot Sel | 3 | Boot device select pins | |
| WDT | 1 | Watch Dog Timer output | |
| MISC | 12 | Power management pins | |
| RSVD / AFB | 20 | Reserved / Alternate Function Blocks (AFB) | AFB's |
| RSVD/EDP_HPDP | 1 | Reserved / Future use for eDP HPDP | |
| Type Pins | 3 | Pin straps used to distinguish Camera Use and I/O Voltage | |
| Power | 11 | 10 pins for Module input power ; 1 for RTC | |
| GND | 48 | Grounds – circa 15% of total pins | |
| Pin Total | 314 | | |

Preliminary

» ULP-COM-sAT30

- nVidia Tegra 3 Quad Core ARM Cortex A9 800MHz
- 1GB memory down
- HD encode/decode MPEG2, dual GPU

Samples Q3



» ULP-COM-sA3874

- Ti AM3874 Single Core ARM Cortex-A8 processor 800MHz/1GHz
- 1GB memory down, PCIe2 w/ integrated PHY,

Samples Q3



» ULP-COM-sAMX6

- Freescale i.MMX6 Single – Dual- Quad Core ARM Cortex-A9 processor
- Full HD 1080P encode/decode, single and dual display support
- On chip LAN and PCIe to connect to external modem, WiFi

Samples Q4

ARM Ecosystem

Hardware

» Starterkit ULP-COM

- Evaluation Carrier 200 x 175 mm
- 10" LDVS Display WXGA
- Touch Controller
- Power Supply / Power Cord
- Mounting Kit

– Optional

- ULP-COM
- Board Support Package
- Cooling solution

Samples Q4



Representative image

Preliminary

On the way to a complete solution



GUI, Application

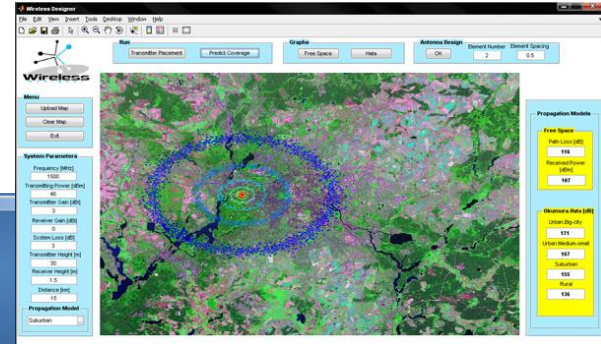

Operating System



BIOS, Firmware,...



ARM COM
from Kontron



- Other devices
- Ethernet Controller
- Network Controller
- PCI Modem

Drivers

FPGA, ASICs,...



Baseboard,



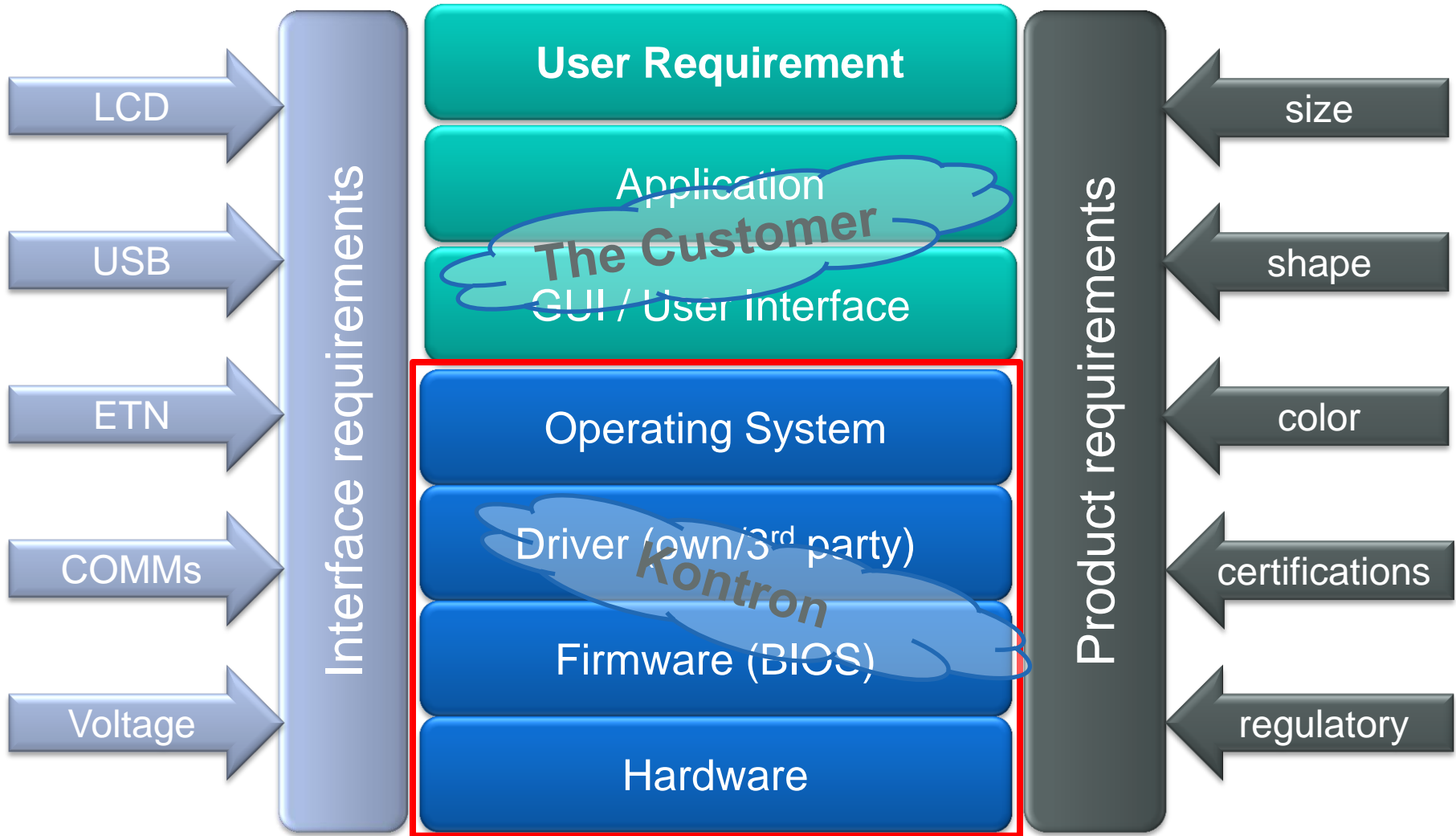

» Board Support Packages

- Validated BSPs for Linux, WEC 7,
- others on request (like VxWorks, QNX, Android, ...)

» Any incremental work on all of the above, like

- App specific performance optimization
- Migration to other hardware or other OSes/RTOSes

» Initial Integration of almost any 3rd party Software stacks incl. Performance- and Compatibility Validation

» Life Cycle Support of these integrations





THANK YOU